

SWISS Belly Charter

Reliable
Customized
Swiss Quality

We care for your cargo.



SWISS Belly Charter

Reliable quality in extraordinary times

To keep supporting the global supply chain and delivering goods on behalf of our precious customers, Swiss WorldCargo is now offering Charter Flights on its Boeing 777-300ER, Airbus A330-300/A340-300 and Airbus A320 Family aircraft.

The unprecedented effects of the corona virus have caused severe impacts to the global aviation and air cargo industries. As a result, we have also had to adjust our standard Swiss WorldCargo network.

Despite the slowdown in global air travel, we are seeing an ongoing demand for the transportation of goods. Such extraordinary times require extraordinary measures. That's why Swiss WorldCargo is introducing its newly designed solution, Belly Charter. To fulfill all shipping needs, two variations of our new service have been defined: Full Belly and Charter Co-Load.

Why SWISS Belly Charter

Your Benefits

- Extremely short acceptance times
- Flexible routing options
- Customized shipping solutions
- Customized quotes
- Personalized customer service
- Highly-efficient transport and handling processes ensure that your cargo gets to its destination extremely quickly and on time
- Online tracking makes it possible to be informed about the status of your shipment
- Delivery possible all over the world

Full Belly

Full Belly is an entire chartered aircraft and meant for one single customer.

To process a request of Full Belly, the following information are necessary to be provided.

- Customer / Company Name / Contact Details
- Routing
- One way / Return
- Full Belly
- Pcs. / Volume / Dims / Weight
- Commodity
- Uplift Date
- Target Price / Budget or Benchmark info if available
- One Off or Regular Flight

Charter Co-Load

Charter Co-Load is an agreement with multiple customers for one full belly flight.

To process a request of Charter Co-Load, the following information are necessary to be provided.

- Customer (Multiple / Origins) / Company Name(s) / Contact Details
- Routing
- One Way / Return
- Co-Load: Number of Units / Unit Type
- Chargeable Weight
- Pcs. / Volume / Dims / Weight
- Commodity
- Ready to sign BSA?
- Uplift Date
- Target Price / Budget or Benchmark info if available
- One Off or Regular Flight



For both variants of SWISS Belly Charter, all inquiries need to be requested to cargo.charter@swiss.com
swissworldcargo.com/belly-charter

Our Fleet



Boeing 777-300ER (77W)

Area of operation

North and South America, Africa, Middle East and Asia

Capacity for cargo and mail

Up to 47 tons with 0 passengers

Possible versions of allocation for cargo and mail

14 Pallets and 0 LD3 Container or 0 Pallets and 44 LD3 Container

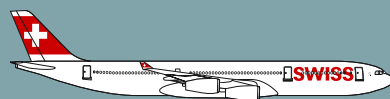

Airbus A340-300 (343)

Area of operation

North and South America, Africa, Middle East and Asia

Capacity for cargo and mail

Up to 32 tons with 0 passengers

Possible versions of allocation for cargo and mail

11 Pallets and 1 LD3 Container or 1 Pallets and 31 LD3 Container

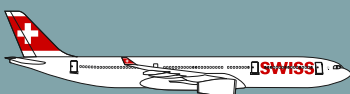

Airbus A330-300 (333)

Area of operation

North and South America, Africa, Middle East and Asia

Capacity for cargo and mail

Up to 29 tons with 0 passengers

Possible versions of allocation for cargo and mail

11 Pallets and 0 LD3 Container or 1 Pallets and 30 LD3 Container



Airbus A320

Area of operation

Europe, North Africa, Middle East

Capacity for cargo and mail

Depends on flight time

Possible versions of allocation for cargo and mail

7 LD3-45 Containers or Pallets

Our Route Network



SWISS in Europe

Amsterdam
Athens
Barcelona
Belgrade
Berlin
Bilbao
Birmingham
Bordeaux

Bremen
Brindisi
Brussels
Bucharest
Budapest
Copenhagen
Dresden
Dublin

Düsseldorf
Florence
Frankfurt
Geneva
Gothenburg
Graz
Hamburg
Hanover

Kiev
Krakow
Leipzig/Halle
Lisbon
Ljubljana*
London City
London Gatwick
London Heathrow

Luxembourg
Madrid
Malaga
Manchester
Milan
Moscow
Munich
Naples

Nice
Niš
Nuremberg
Oslo
Palma de Mallorca
Paris
Porto
Prague

Pristina
Rome
Saint Petersburg
Stockholm
Stuttgart
Valencia
Venice
Vienna

Warsaw
Wrocław
Zurich

• SWISS destinations
• New SWISS destinations
* Winter destinations

Our Unit Load Devices (Containers)

For SWISS Belly Charter, the following two container options are available.

IATA CODE: AKH

Loadable:

319 / 320 / 321

Usable loading area:

145 × 143 cm / 57 × 56 in

Max. height:

111 cm / 44 in

Top Length:

243 cm / 96 in

Tare weight:

82 kg / 180 lbs

Max. gross weight:

1134 kg / 2500 lbs

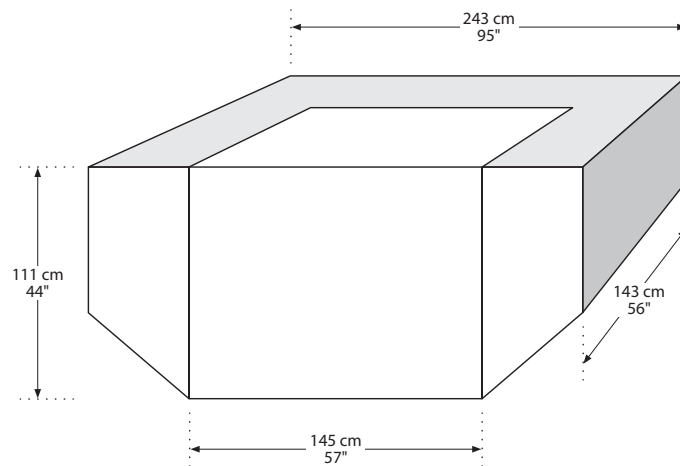

IATA CODE: AKE

Loadable:

333 / 343 / 77W

Usable loading area:

146 × 144 cm / 57 × 57 in

Max. height:

153 cm / 60 in

Top Length:

193 cm / 76 in

Tare weight:

66-88 kg / 145-194 lbs

Max. gross weight:

1587 kg / 3500 lbs

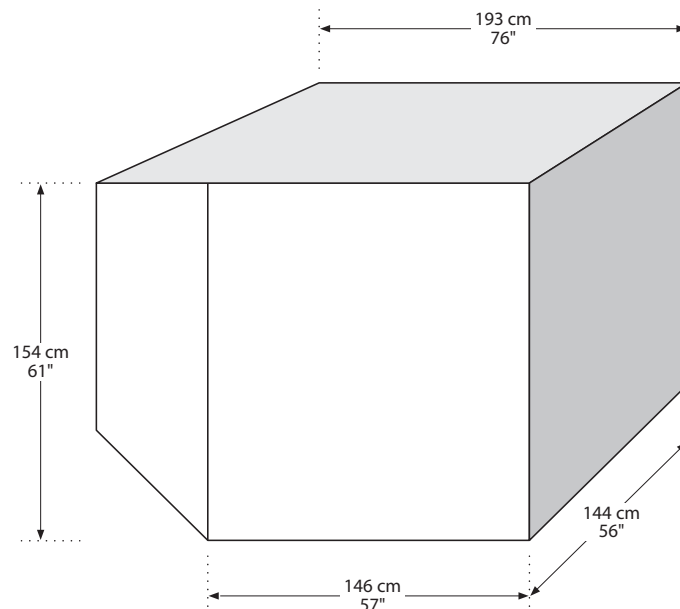

Our Unit Load Devices (Pallets)

For SWISS Belly Charter, the following three pallet options are available.

IATA CODE: AMP

Loadable:

333 / 343 / 77W

Usable loading area:

305 × 223 cm / 120 × 88 in

Max. height:

154 cm / 61 in

Tare weight:

270 kg / 595 lbs

Max. gross weight:

5103 kg / 11250 lbs

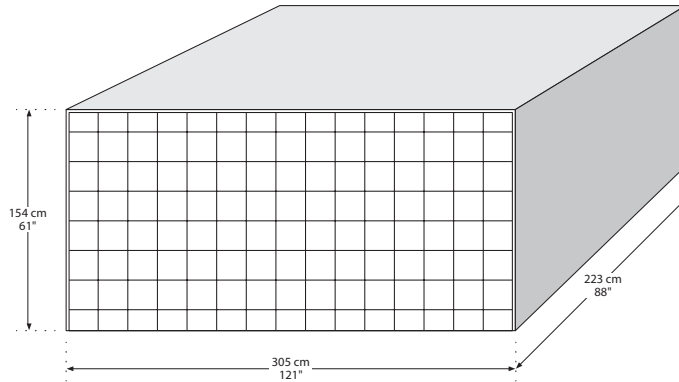

IATA CODE: PMC

Loadable:

333 / 343 / 77W

Usable loading area:

304 × 230 cm / 120 × 91 in

Max. height:

160 cm / 63 in

Tare weight:

110 kg / 242 lbs

Max. gross weight:

5103 kg / 11250 lbs

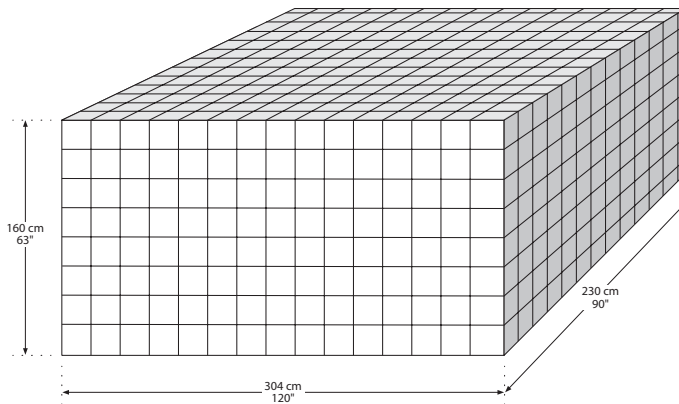

IATA CODE: PKC

Loadable:

319 / 320 / 321

Usable loading area:

145 × 143 cm / 57 × 56 in

Max. height:

114 cm / 45 in

Tare weight:

40 kg / 88 lbs

Max. gross weight:

1134 kg / 2500 lbs

